

ANOMALOUS CURRENTS, INDUCED CHARGE AND BOUND STATES ON A DOMAIN WALL OF A SEMICONDUCTOR*

Daniel BOYANOVSKY

*Stanford Linear Accelerator Center, Stanford University, Stanford, California, 94305, USA
and Physics Department, University of California, Davis, California 95616, USA*

Elbio DAGOTTO

*Department of Physics, University of Illinois at Urbana-Champaign, 1110 West Green Street,
Urbana, IL 61801, USA*

Eduardo FRADKIN

*Department of Physics[†] University of Illinois at Urbana-Champaign, 1110 West Green Street,
Urbana, IL 61801, USA
and Laboratorio de Física Teórica, Universidad de La Plata, C. C. No. 67,
1900 La Plata, Argentina*

Received 12 December 1986

We study the electrodynamics of a PbTe-type bulk semiconductor with a domain wall. We show the existence of states bound to the wall. In the presence of static electric and magnetic fields a current with abnormal parity and a nonzero induced electric charge are shown to exist. These systems are a physical realization of the parity anomaly of $2 + 1$ dimensional QED.

1. Introduction

In relativistic field theories of Fermi systems it is quite common to find situations in which classical symmetries are not respected at the quantum level. Such a situation is generally called an anomaly. The result is typically that a classically conserved current is found not to be conserved quantum mechanically. Another milder form of anomaly is found, for example, in electrodynamics in two space dimensions. In this case the electromagnetic current, although perfectly conserved, is found to violate parity (or rather *CP*) [1].

In condensed matter physics one very rarely finds an anomaly of any of these types. The electrons in metals and semiconductors are non-relativistic and the chiral symmetry involved in the anomaly do not exist in that case. One might want to argue that the electrons are truly relativistic but one is observing a system at finite density. For instance an attempt has been made to explain the quantum Hall effect [2] observed in two-dimensional systems such as MOSFETS in terms of the parity

* Work supported by the Department of Energy, contract DE-AC03-76SF00515.

[†] Permanent address.

anomaly [3, 4] of 2 + 1 dimensional electrodynamics. This attempt failed for rather subtle reasons [5, 6] (see sect. 4). Alternatively one might want to consider lattice systems in which the band structure is such that the spectrum is effectively relativistic. For example, Semenoff [7] has proposed the study of “two-dimensional graphite”. However, he found that the odd parity current is cancelled due to the pervasive doubling properties of lattice relativistic systems.

The purpose of this paper is twofold. On the one hand we want to show how bulk systems always fail to exhibit the parity anomaly. On the other hand, we also show that certain lattice systems, such as PbTe, whose bulk states can be described in terms of massive relativistic fermions (with a mass of the order of the gap) do exhibit the parity anomaly of 2 + 1 dimensional electrodynamics if a structural domain wall (or stacking fault) is included in the system: a shorter version of this paper has been published elsewhere [8]. In fact the states bound to the wall are responsible for the anomaly. This idea, inspired by a seminal paper by Callan and Harvey [9] points towards the rather important changes in the physics of the electronic states of systems with defects. For instance it is quite likely that dislocations and other forms of topological disorder may produce similar effects.

To the best of our knowledge, apart from our proposal, the only other successful use of anomalies in condensed matter physics has only been achieved in the study of mass currents in superfluid He³A with chiral textures [10–12]. Our study also points to a close analogy with the physics of fractional charge in one-dimensional systems with solitons [13, 14]. In addition our analysis shows a possible way to study lattice systems with chiral fermions by considering a lattice gauge theory in higher dimensions (say five) in the background of soliton.

The paper is organized as follows. In sect. 2 a simple tight-binding model for PbTe-type system is introduced and the equivalence with lattice Dirac (Kogut-Susskind) fermions is shown. A domain wall is introduced and the system is shown to be equivalent to relativistic fermions coupled to a soliton. In sect. 3 the electrodynamics of fermions in a soliton background is studied. It is shown that the electromagnetic current has an abnormal parity contribution equal to

$$J_\mu = s \frac{4e^2}{\hbar} \frac{1}{4\pi} \epsilon_{\mu\nu\lambda} \partial^\nu A^\lambda, \quad (1.1)$$

where $\mu = 0, 1, 2$ (time, x and y) and s is a sign that depends on the way the ground state is filled. In sect. 4 we show why is it that in very general terms a system on a two-dimensional Bravais lattice does not exhibit the anomaly and neither would continuum massive relativistic fermions constrained to move on a surface. In sect. 5 we consider the effects of a Zeeman interaction and of a Peierls distortion. We also discuss the behavior of the magnetic susceptibility. Sect. 6 is devoted to the conclusions.

2. The model

In ref. [8] we introduced a phenomenological tight-binding model for the electronic states of PbTe in the background of a domain wall. We now proceed to briefly summarize its properties. We first discuss the pure system and later consider two types of defects: (a) a domain wall, and (b) an open surface.

PbTe is a narrow-gap-semiconductor (NGS) [15] in which the minimum of the conduction band and the maximum of the valence band are closest at the L points of the Brillouin zone, i.e. $(\pm \frac{1}{2}\pi, \pm \frac{1}{2}\pi, \pm \frac{1}{2}\pi)$. This effect appears to be due mainly to the strength of the spin-orbit interaction. Since other bands are unimportant to the physics of the states close to the Fermi energy we can introduce a simple phenomenological tight-binding hamiltonian which has essentially the same properties for states close to the L points. Let us then consider a system on a rock-salt structure. The Pb atoms sit on one cubic sublattice and the Te atoms on the other one. Consider two states per site (up and down spins). Let $\phi_\alpha^+(\mathbf{r})$ denote the operator which creates an electron of spin α at site \mathbf{r} . We now mimic the effects of a strong spin-orbit interaction by a spin-dependent hopping amplitude of the form $T\sigma_i$ (for hopping in the i th direction) where σ_i is the i th Pauli matrix and T is the strength. In addition there is a site diagonal (spin-independent) term which equals M for Pb sites and $-M$ for Te sites. The hamiltonian is

$$H = \sum_{\substack{\mathbf{r}, i=1,2,3 \\ \alpha, \beta=\uparrow, \downarrow}} [T\phi_\alpha^+(\mathbf{r})\sigma_i^{\alpha\beta}\phi_\beta(\mathbf{r}+e_i) + \text{h.c.}] + \sum_{\substack{\mathbf{r} \\ \alpha=\uparrow, \downarrow}} M(-1)^{x+y+z}\phi_\alpha^+(\mathbf{r})\phi_\alpha(\mathbf{r}), \quad (2.1)$$

where $\{e_i\}$ are nearest-neighbor lattice vectors. The states created by $\phi_\alpha^+(\mathbf{r})$ are linear combinations of p -like Wannier states which participate in the near-crossing phenomenon.

It is a matter of elementary algebra to verify that the spectrum of this hamiltonian is

$$E(\mathbf{k}) = \pm \sqrt{M^2 + T^2 \sum_i \cos k_i}. \quad (2.2)$$

Thus, at the L points of the BZ, the energy gap is minimum with magnitude $2M$. For the NGS system like PbTe the gap is typically [15] of the order of 0.1 eV. Thus the spectrum of states near the Fermi energy is similar to the spectrum of massive relativistic fermions with mass $m \sim M/T$. In fact by means of a simple change of variables it is possible to show that eq. (2.1) is equivalent to a discrete versions of the Dirac hamiltonian. This is shown most simply by spin diagonalizing the system. We write

$$\phi_\alpha(\mathbf{r}) = i^{x+z}(-1)^{y(y+1)/2}(\sigma_1^x \sigma_2^y \sigma_3^z)_{\alpha\beta} \phi_\beta(\mathbf{r}), \quad (2.3)$$

where x, y, z are integers and α, β label the spin components. The hamiltonian now

is

$$\begin{aligned}
 H = \sum_{\mathbf{r}, \alpha} T \{ & \psi_{\alpha}^{+}(\mathbf{r}) i [\psi_{\alpha}(\mathbf{r} + \hat{e}_1) - \psi_{\alpha}(\mathbf{r} - \hat{e}_1)] \\
 & - \psi_{\alpha}^{+}(\mathbf{r}) (-1)^{x+y} [\psi_{\alpha}(\mathbf{r} + \hat{e}_2) - \psi_{\alpha}(\mathbf{r} - \hat{e}_2)] \\
 & + \psi_{\alpha}^{+}(\mathbf{r}) i (-1)^{x+y} [\psi_{\alpha}(\mathbf{r} + \hat{e}_3) - \psi_{\alpha}(\mathbf{r} - \hat{e}_3)] \} \\
 & + \sum_{\mathbf{r}, \alpha} M (-1)^{x+y+z} \psi_{\alpha}^{+}(\mathbf{r}) \psi_{\alpha}(\mathbf{r}). \tag{2.4}
 \end{aligned}$$

This is the form of the hamiltonian for Kogut-Susskind fermions [16] (with two species of fermions, up and down) which is a discretization of the Dirac hamiltonian. We follow ref. [16] and identify the behavior of the states near the Fermi energy with that of the Dirac theory in a continuum. As shown by Susskind [16], eq. (2.4) describes two species (four including spin) of Dirac fermions. Roughly speaking there are two sets of independent linear combinations of the eight amplitudes on an elementary cube which constitute the two Dirac fermionic species (four including spin). In terms of these fields we can write an effective continuum hamiltonian of the form

$$H = \sum_{\alpha=\uparrow, \downarrow} \int d^3x \{ -\eta_{\alpha}^{+} i \boldsymbol{\alpha} \cdot \nabla \eta_{\alpha} - \chi_{\alpha}^{+} i \boldsymbol{\alpha} \cdot \nabla \chi_{\alpha} + m \eta_{\alpha}^{+} \beta \eta_{\alpha} + m \chi_{\alpha}^{+} \beta \chi_{\alpha} \}, \tag{2.5}$$

where $\boldsymbol{\alpha}, \beta$ are the Dirac matrices, η and χ are the two species of fermions and $m = M/T$ is the mass. For details, see the appendix. Furthermore, the current and charges of the semiconductor problem have a simple representation in terms of the Dirac fermion. In particular, the electromagnetic current of the semiconductor is the sum of the electromagnetic current of the four Dirac species. Thus, it suffices to study the properties of continuum Dirac fermions in an electromagnetic field. The current we are interested in is simply four times larger. This is a crucial point for our study. From studies in lattice gauge theory it is known that the double species normally lead to a local cancellation of anomalies [17]. As it is discussed in sect. 4 this is indeed the case for a two-dimensional version of this model. The introduction of defects radically alters this picture. As we show below (and in the next section) in the presence of a domain wall or, in certain cases, of an open surface, an anomaly may still be present due to the existence of zero-modes. This phenomenon was first discovered within the framework of continuum field theory by Callan and Harvey [9]. What we show here is that the Callan-Harvey mechanism works also in lattice systems.

Thus we now proceed to discuss the physics in the presence of defects. As it will become clear immediately, there is a very close analogy between our problem and

the problem of one-dimensional lattice systems with solitons, e.g. polyacetylene. In particular the Callan-Harvey-type modes are the analogs of the midgap states.

2.1. DOMAIN WALL

Consider a system with a domain wall (or stacking fault) (see fig. 1). Such defects are suppressed since their energy grows like the area of the defect. However they can arise in the course of crystal growth under specially prepared circumstances. At the level of phenomenological hamiltonian, eq. (2.1), this can be implemented by replacing M by $-M$ on half of the system or, what is the same, exchange all Pb and Te atoms to the right of a plane half way through the system. Thus the mass becomes position dependent with a profile (for a sharp wall) $M(\mathbf{r}) = M\epsilon(z)$, where z is the (integer) coordinate along the z direction. As shown in the appendix, the system now has, in addition to the extended bulk states, "zero-modes" localized on the wall. The energy of these modes is

$$E(p_1, p_2) = \pm 2T \sqrt{\sin^2 \frac{p_1}{2} + \sin^2 \frac{p_2}{2}}, \quad (2.6)$$

with $|p_1|, |p_2| \leq \pi$. The wave functions decay on both sides of the wall like $e^{-K|z|}$ where K is given by

$$\frac{M}{2T} = \sinh \frac{K}{2}. \quad (2.7)$$

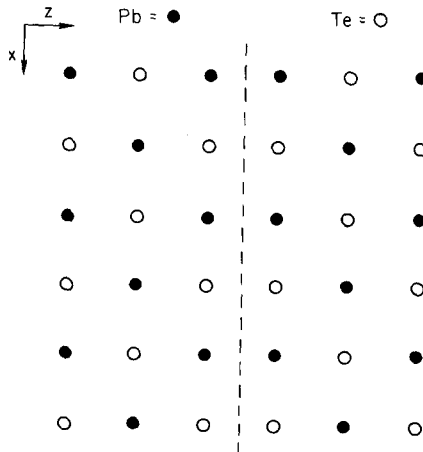

Fig. 1. Two-dimensional view of the PbTe system with a domain wall (dotted line) on the (001) axis. Note that the phase to the right of the wall can be obtained from the phase to the left by a lattice displacement of half a unit.

The amplitude of the “zero-mode” wave functions are different on each of the eight sublattices (see appendix). Formally, the “zero-modes” correspond to a lattice version of the massless Dirac spectrum *without additional doubling*. In the continuum limit, the domain wall becomes a varying mass $m(z) = M(z)/T$. Since $m(z)$ varies between the values $+M/T$ and $-M/T$ we identify this defect with a soliton. Thus, in the continuum limit, we get an effective hamiltonian of the form eq. (2.5) in a soliton background. What is crucial for our discussion is that *all doubled species* (i.e. the η 's and χ 's with both spin orientations) *couple to the soliton in the same way*, i.e. with the same sign of the mass. As it is discussed in sect. 4, while this is possible in three dimensions, this is not the case in two dimensions (i.e. a single plane of atoms) where different species couple with opposite signs of the mass.

2.2. FREE SURFACE

Consider now a system without soliton, but with an *odd* number of lattice planes in one direction. If we now imagine building up the system periodically, it is then clear that the extra plane is equivalent to the insertion of a soliton. Thus a system without a soliton but with an open surface must have the very same “zero-mode” states present in systems with solitons. Notice, however, that if the number of planes is even, no such states will be present. A very similar situation takes place in one-dimensional systems, as is shown in the work by Bell and Rajaraman [18].

3. Parity anomaly and bound states on the domain wall

In the previous chapter we have shown that the physics of the low-lying excitations in a PbTe-type semiconductor can be modeled by a relativistic theory of massive fermions.

This section is devoted to the understanding of the ground state properties of the theory at the level of the effective Dirac equation. In the real system we have effectively four species of the Dirac fermions, two originating from lattice doubling and another two from the spin degrees of freedom. In the absence of interactions or for static background fields, these species decouple yielding induced charge and currents four times larger than in a single-species theory. In this section we will work with a continuum Dirac theory with only one species.

As is familiar from the situation in charge density waves systems in one dimension, we will invoke the Born-Oppenheimer approximations. This amounts to neglecting the back-reaction of the fermionic degrees of freedom onto the bosonic ones. Therefore in this approximation, the fermions interact with an external background field assumed to be static. In this problem this approach is essentially exact since the energy of the soliton being proportional to the area in the x - y plane is very large.

3.1. THE SOLITON IN ZERO ELECTROMAGNETIC FIELD

As described before, after linearizing the fermion spectrum near the L -degeneracy points on the Fermi surface, we are led to the following Dirac-type hamiltonian

$$H = -i\boldsymbol{\alpha} \cdot \nabla + \beta M(z), \quad (3.1)$$

where we have introduced the effect of an antiphase boundary (domain-wall) in the direction (001), through the position dependent mass term $M(z)$.

We will assume that $M(z = \pm\infty) = \pm M$ ($M > 0$). The topology of this domain wall ensures the existence of fermionic states localized (near $z = 0$) within a distance $l \approx M^{-1}$. These states are solutions of $H_z \psi_0 = 0$ with

$$H_z = -i\alpha_z \partial_z + \beta M(z). \quad (3.2)$$

Choosing the representation in which $\gamma^3 = \beta\alpha_z = i\alpha_3 \otimes \sigma_3$, the solutions of eq. (3.2) are eigenstates of γ^3 with eigenvalues $\pm i$. They are given by

$$\psi_+ = N \left[\begin{pmatrix} 1 \\ 0 \\ 0 \\ 0 \end{pmatrix} + a \begin{pmatrix} 0 \\ 0 \\ 0 \\ 1 \end{pmatrix} \right] \exp\left(-\int^z M(z') dz'\right), \quad (3.3)$$

$$\psi_- = N \left[\begin{pmatrix} 0 \\ 1 \\ 0 \\ 0 \end{pmatrix} + b \begin{pmatrix} 0 \\ 0 \\ 1 \\ 0 \end{pmatrix} \right] \exp\left(\int^z M(z') dx'\right). \quad (3.4)$$

If $M(z = \pm\infty) = \pm M$ ($M > 0$) only the state given by eq. (3.3) is normalizable, the state given by eq. (3.4) is normalizable for $M < 0$. These solutions are eigenstates of

$$H_{\perp} = -i\boldsymbol{\alpha}_{\perp} \cdot \nabla_{\perp}, \quad \nabla_{\perp} = \left(\frac{\partial}{\partial x}, \frac{\partial}{\partial y} \right).$$

This is so because H_{\perp} and H_z anticommute. Therefore the solutions localized near the domain wall (along the z -direction) are of the form

$$\psi \propto \begin{pmatrix} 1 \\ 0 \\ 0 \\ e^{\pm i\theta} \end{pmatrix} \exp\left(-\int^z M(z') dx'\right), \quad \tan \theta = \frac{k_y}{k_x}, \quad (3.5)$$

with energy $E = \pm \sqrt{k_x^2 + k_y^2}$. Therefore, these localized states act like massless fermions moving on the x - y plane near $z = 0$ (compare E to eq. (2.6)). In fact since

they only have two non-zero components, they behave as two-dimensional massless Dirac fermions. The spectrum of H also has a positive and negative energy continuum (conduction and valence bands) starting at $E = \pm |M|$.

The hamiltonian H in eq. (3.1) has particle-hole symmetry. In fact the operator $\beta\alpha_x\alpha_y\alpha_z$ anticommutes with H ensuring that the spectrum is symmetric around $E = 0$. Hence if there are other bound states at $E \neq 0$ these appear in pairs of opposite energies. In one-dimensional charge density waves systems the existence of the midgap bound states is responsible for induced fractional charges in the ground state [13]. Therefore we are led to the question of whether there is a charge induced by these localized modes.

The ground state charge is defined as

$$Q = \int_{-\infty}^{0^-} [\rho_w(E) - \rho_0(E)] dE, \quad (3.6)$$

where $\rho_w(E), (\rho_0(E))$ is the density of states in the presence (absence) of the domain wall. The definition in eq. (3.6) amounts to subtracting the charge of the (filled) valence band without the domain wall. It corresponds to a particular normal ordering of the charge operator.

As usual, using completeness it can be written as

$$Q = -\frac{1}{2} \int_0^\infty [\rho_w(E) - \rho_w(-E)] dE. \quad (3.7)$$

The integral on the right-hand side of eq. (3.7) measures the asymmetry between the positive and negative energy parts of the spectrum. In the case when there is particle-hole symmetry only the normalizable $E = 0$ states contribute to the charge.

However, in our case the midgap states given by eq. (3.5) correspond to massless two-dimensional relativistic particles which have a continuum spectrum. Hence the density of states $\rho_w(E) \propto E$ (near $E = 0$). Therefore the continuity of the spectrum precludes the existence of any induced charge. In contrast in one-dimensional systems with solitons, the spectrum has a discrete component and the charge is non-zero.

In fact we can prove quite generally that more than just domain walls are needed in three space dimensional to induce an asymmetry in the spectrum (see eqs. (3.6), (3.7)).

For this we generalize the hamiltonian eq. (3.1) to read

$$\tilde{H} = -i\alpha \cdot \nabla + \beta M(z) - i\beta\gamma^5 K(z). \quad (3.8)$$

Here $\gamma^5 = \alpha_x\alpha_y\alpha_z$. The last term in \tilde{H} breaks the particle-hole symmetry and corresponds to introducing a ‘‘chiral kink’’. In sect. 5 we present a physical realization of this term. However, the case of the scalar soliton can be recovered

setting $K(z) = K = \text{const}$ and $K \rightarrow 0^\pm$. From now on we set $K(z) = K$. The virtue of this term is that now the localized states given by eq. (3.5) have energy $E = \pm \sqrt{k_x^2 + k_y^2 + K^2}$. Writing

$$M(z) = i\gamma^5 K = \rho(z) e^{-i\gamma^5 \theta(z)}, \quad \theta(z) = \tan^{-1} \left(\frac{K}{M(z)} \right) \quad (3.9)$$

and performing a chiral change of variables on the single particle wave functions*

$$\psi(\mathbf{x}) = e^{i\gamma^5 \theta(z)/2} \chi(\mathbf{x}). \quad (3.10)$$

The spinors χ obey

$$\left[-i\boldsymbol{\alpha} \cdot \nabla + \beta\rho(z) + \frac{1}{2}\gamma^5 \boldsymbol{\alpha} \cdot \nabla\theta(z) \right] \chi = E\chi. \quad (3.11)$$

In eq. (3.11) we recognize the combination $\gamma^5 \boldsymbol{\alpha} = \boldsymbol{\Sigma}$, where $\boldsymbol{\Sigma}$ is the Dirac spin. This *Dirac spin should not* be confused with the spin of the lattice states of the previous chapters. The spinors η and χ in eq. (2.5) are obtained after formal manipulations (linear combinations and spin diagonalization (eq. (2.3)) on the original orbitals in the valence and conduction bands of eq. (2.1)).

As usual the way to understand the origin of the spectral asymmetry is to square the Dirac eq. (3.11). We obtain

$$\left[-\nabla^2 + \rho^2 + E\boldsymbol{\Sigma} \cdot \nabla\theta(z) - \frac{1}{4}(\boldsymbol{\Sigma} \cdot \nabla\theta)^2 \right] \chi = E^2 \chi, \quad (3.12)$$

where we dropped derivatives of $\rho(z)$ as they are not important (independent of E).

In the one-dimensional case the term $E\boldsymbol{\Sigma} \cdot \nabla\theta$ is replaced by $E d\theta/dx$, i.e. particles with opposite energy scatter off opposite “potentials”. This is the origin of the asymmetry in one space dimension.

For a kink in the z -direction, the term in eq. (3.12) that would be responsible for the asymmetry is $E\Sigma_z d\theta(z)/dz$. Now the “potential” is “spin” dependent. In fact the “spin” is responsible for the vanishing asymmetry. “Spin” up (along the z -direction) positive energy particles interact with the *same* potential as “spin” down negative energy particles. (The quotes on “spin” refer to the fact that it *should not* be confused with the spin of the physical, original fermions. This “spin” involves a combination of orbital fermions.)

For “spin”-up particles the asymmetry is minus that of the “spin”-down particles. Hence we see that the “spin” degree of freedom conceals the total asymmetry

* This chiral rotation is performed at the level of the single particle wave functions, not on the second-quantized field operators. In the path integral quantization, there is a jacobian associated with this change of variables. However, this jacobian does not involve the fermion degrees of freedom and is of no interest for the present discussion [19].

thereby yielding zero total charge in the ground state. Strictly speaking the above analysis is not very rigorous since for a domain wall in the z -direction the total angular momentum $J_z = L_z + \frac{1}{2}\Sigma_z$ is a good asymmetry, but not Σ_z separately.

However for $K \neq 0$ in (3.8) and (3.9) the states localized near the domain wall are massive and have a rest frame. In their rest frame Σ_z is a good quantum number and the arguments given above apply. Clearly for the rest of the spectrum the argument is valid since these are all massive states. The fact that the two allowed values of spin prevents any asymmetry in the spectrum (and ground state charge) has also been noticed in ref. [6]. There the same argument was used to show that four-component spinors do not have parity anomalous properties in 2 + 1 dimensions.

Now we see that the domain wall produces a dimensional reduction. The states bound to the wall are in fact two-dimensional and have all the properties of the 2 + 1 dimensional theories. From eqs. (3.2), (3.3), (3.4) we see that they have only two non-zero components. For $K > 0$ (with $K = \text{const}$) we see from (3.8) that positive and negative energy spinors are of the form

$$\begin{aligned} \psi_{+ E > 0} &\propto \begin{pmatrix} 1 \\ 0 \\ 0 \\ \frac{k_x - ik_y}{E + K} \end{pmatrix} \exp\left(-\int^z M(z') dx'\right), \\ \psi_{+ E < 0} &\propto \begin{pmatrix} \frac{k_x + ik_y}{E - K} \\ 0 \\ 0 \\ 1 \end{pmatrix} \exp\left(-\int^z M(z') dz'\right). \end{aligned} \tag{3.13}$$

Therefore they only have *one* spin projection and $E > 0$ have spin up and $E < 0$ spin down in the rest frame. For $K < 0$ there is the opposite spin assignment.

3.2. THE SYSTEM IN A NON-ZERO STATIC UNIFORM MAGNETIC FIELD

From the discussion above, and the results of 2 + 1 dimensional theories we now see that an external magnetic field with a component *perpendicular* to the domain wall (i.e. parallel to \hat{z}) will induce a charge in the ground state. In fact this magnetic field lifts the spin degeneracy, thereby producing an asymmetry in the spectrum. We then study the system in an external constant magnetic field in the \hat{Z} direction. In the Landau gauge $A_\mu = (0, 0, BX, 0)$ the hamiltonian is $H = H_0 + H_1$ with

$$\begin{aligned} H_0 &= -i\alpha_x \partial_x + \alpha_y (-i\partial_y - BX), \\ H_1 &= -i\alpha_z \partial_z + \beta M(z) - i\beta\gamma^5 K. \end{aligned} \tag{3.14}$$

In what follows we assume that $B > 0$. Notice that H_0 and H_1 anticommute. This means that the “zero modes” of the H_0 can be chosen to be eigenstates of H_1 .

The eigenstates of H_0 are the familiar relativistic Landau levels. The “zero modes” (lowest Landau branch) are of the form

$$\chi_0 \propto \begin{pmatrix} 1 \\ 0 \\ c \begin{pmatrix} 1 \\ 0 \end{pmatrix} \end{pmatrix} \exp\left(\frac{1}{2}B(x - x_0)^2\right) e^{ik_y y}, \tag{3.15}$$

with $x_0 = k_y/B$ the center of the Landau orbit. Therefore we see that in the lowest Landau branch, the problem is effectively one-dimensional (i.e. along the z axis). The (normalizable) states localized on the wall are of the form

$$\Phi_0 = N \begin{pmatrix} 1 \\ 0 \\ 0 \\ 0 \end{pmatrix} \exp\left(-\int^z M(z') dz'\right) \exp\left(-\frac{B}{2}(x - x_0)^2\right) e^{ik_y y}, \tag{3.16}$$

with energy $E = +K$. For $B < 0$, replace $|B|$ in eq. (3.16) and the column spinor has the 1 in the lowest entry. The energy of these modes is now $E = -K$. These modes are occupied or not depending on the sign of K . They are occupied for $B > 0, K < 0$ or $B < 0, K > 0$ and empty otherwise. Note the important dependence on the sign of B . For the lowest Landau branch we can use the results of one dimension. Since the number of states per unit area (on the x - y plane) in the lowest Landau branch is $B/2\pi$ we have ($A = \text{area}$)

$$\frac{Q}{A} = \frac{e^2}{\hbar c} \left(\frac{\Delta\theta}{2\pi}\right) \frac{B}{2\pi} \cdot 4, \quad \Delta\theta = \theta(z = +\infty) - \theta(z = -\infty), \tag{3.17}$$

where $\theta(z)$ is given in eq. (3.9) and we have restored standard units and the extra factor of 4 (species doubling and spin). As $K \rightarrow 0^\pm$ ($\Delta\theta \rightarrow \mp\pi$)

$$Q = \mp \frac{1}{2} \frac{BA}{2\pi} \frac{4 \times e^2}{\hbar c}. \tag{3.18}$$

This is the right answer when there is particle-hole symmetry ($K = 0$). In this case the total charge is given by $Q = \pm \frac{1}{2}N_0$ where N_0 is the number of zero energy states of H . The sign ambiguity in (3.18) is because as $K \rightarrow 0^+$ (0^-) these states are empty (occupied).

The fact that only the lowest Landau level contributes to the asymmetry and therefore to the charge can be seen as follows. As was argued before an asymmetry in the spectrum can only be introduced by producing an asymmetry in “spin”. It is easy to see that the spectrum of H_0 in eq. (3.14) is given by (for $B > 0$)

$$\begin{aligned} \epsilon_n &= \pm \sqrt{(2n + 1)B - \Sigma_z B}, & n \neq 0, \\ \epsilon_0 &= 0, & n = 0, \quad \Sigma_z = +1, \end{aligned} \tag{3.19}$$

where the lowest Landau level corresponds to ϵ_0 . From eq. (3.19) we see that for $n \neq 0$ (higher) Landau levels $\epsilon(n, \Sigma_z = +1) = \epsilon(n - 1, \Sigma_z = -1)$. Therefore for $n \neq 0$ all the levels are “spin” paired and *only* the lowest level is asymmetric in spin.

Hence the total charge induced is given by eq. (3.17), this expression can be written as

$$Q = - \int d^3x \frac{1}{8\pi^2} \epsilon^{0ijk} \partial_i \theta F_{jk} \times \frac{4e^2}{\hbar c} . \tag{3.20}$$

By Lorentz covariance, we find the induced currents

$$\langle J^\mu \rangle = - \frac{1}{8\pi^2} \epsilon^{\mu\nu\rho\sigma} \partial_\nu \theta F_{\rho\sigma} \times \frac{4e^2}{\hbar c} + \dots , \tag{3.21}$$

where the dots stand for terms higher in derivatives that do not contribute to the integrated charge. Eq. (3.21) is the result obtained by Callan and Harvey [9] for fermionic theories with axion strings. *This is the main result of this paper.*

However our analysis clarifies the relationship of the current (3.21) to the parity anomaly in 2 + 1 dimensions and fractional charges in one dimension. Furthermore notice that the sign ambiguity in eq. (3.18) is given by the sign of K , i.e. the sign of the mass of the fermions that live on the two-dimensional domain wall. Eq. (3.21) predicts that when there is an external electric field there are currents perpendicular to it *even in the absence* of a magnetic field (fig. 2). See the discussion at the end of this section. This can be understood in several ways. Lorentz covariance implies that in a frame moving with velocity E/B along the x direction, there is an electric field $E = E\hat{e}_y$. However by eq. (3.17) there is a current in the x -direction. The integral of

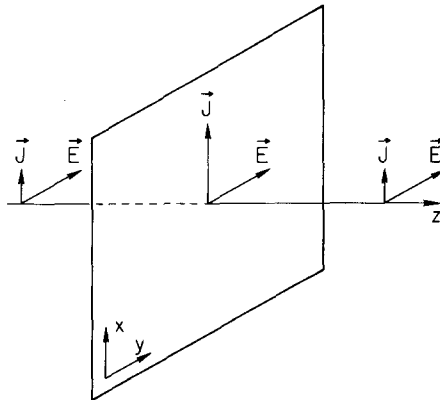

Fig. 2. An external electric field E along the wall induces a current J perpendicular to E . The current decreases away from the wall because the wave function is exponentially small at $|z| \gg 1$.

this current is

$$J_x = \frac{\Delta\theta}{2\pi} \frac{E_y}{2\pi} A \times \frac{4e^2}{\hbar}. \quad (3.22)$$

However as was mentioned in refs. [5] and [6] these are *not* Hall currents, their physical origin is quite different.

In fact these currents have their origin in a type of spin-orbit effect. Consider an electric field parallel to the domain wall. The states bound to the wall have “spin” up for $E > 0$ and “spin” down for $E < 0$ (see eq. (3.13)). Those particles moving perpendicular to the electric field (in the two-dimensional subspace) will feel a magnetic field in the \hat{z} direction (in their rest frame). This magnetic field will attract particles with “spin” parallel and repel those with “spin” antiparallel. The currents described by (3.22) are “spin” currents *unlike* the Hall currents. In fact these are the Chern-Simons currents that arise in 2 + 1 dimensional models. In fact one may think that in the Hall effect, the lowest Landau level completely filled gives a charge per unit area $Q_H/A = e|B|/2\pi$ since the total number of states is $|B|A/2\pi$. This is to be contrasted with the result $Q/A \sim B$, including the sign of B , since it is the sign of B that determines whether the normalizable states given by (3.16) have energy $E = \pm K$. Hence the sign of B determines whether these states are empty or occupied, therefore Q changes sign with B . Again this is because for opposite sign of B the opposite spin is polarized parallel to B [6].

Then moving to a frame with velocity $\mathbf{v}_d = (\mathbf{E} \times \mathbf{B})/B^2$, in this frame there is a current $J^i \propto \varepsilon^{ij} E_j B/|B|^2 \times (B) \propto \varepsilon^{ij} E_j$. Again unlike the Hall currents $J_H^i \propto \varepsilon^{ij} E_j \text{sign}(B)$. This in fact suggests that the currents given by eq. (3.22) can be measured in a Hall experiment by changing the direction of the magnetic field. The currents eq. (3.22) *do not change sign*. Our discussion leading to eqs. (3.17), (3.18) and (3.22) is restricted to $E^2 - B^2 < 0$ (magnetic-like static fields). For $E^2 - B^2 > 0$ or for pure electric-like effects we cannot consider a constant electric field because of pair-production. However one can consider a weak, localized electric field (like a charged impurity) and use perturbation theory to compute the induced currents. This was the approach of ref. [6] leading to a contribution given by eq. (3.22). We have only looked at the parity odd terms, but it is very easy to see (for example using linear-response and perturbation theory), that there is another contribution to the current besides (3.22). It is longitudinal and hence dissipative but does not present the odd properties of the above currents, and do not depend on the structural defects.

4. Problems in two-space dimensions

As described in sect. 1, our purpose is to find out a physical realization of the parity “anomaly” in two spatial dimensions. For this reason we have introduced the domain wall in the PbTe semiconductor.

Although one may think that there are more straightforward approaches to two-dimensional physics, it can be proved that in many cases there are subtle cancellations leading to a zero anomalous current. Let us discuss this point in detail.

The simplest method to generate a 2 + 1 dimensional theory is to constrain a system of three-dimensional Dirac particles to move in a plane using some kind of external potential. To describe this situation, one can roughly say that in the Dirac equation

$$[i\gamma^\mu(\partial_\mu - ieA_\mu) + m]\psi = 0 \quad (\mu = 0, 1, 2, 3), \tag{4.1}$$

we consider $p_3 = -i\partial_3 \equiv 0$ (and fix the gauge $A_3 = 0$). ψ is still a four-component object. It is convenient to work in the following representation of Dirac matrices [20]

$$\begin{aligned} \gamma^0 &= \begin{pmatrix} \sigma_3 & 0 \\ 0 & -\sigma_3 \end{pmatrix}, & \gamma^1 &= i \begin{pmatrix} \sigma_1 & 0 \\ 0 & -\sigma_1 \end{pmatrix}, & \gamma^2 &= i \begin{pmatrix} \sigma_1 & 0 \\ 0 & -\sigma_2 \end{pmatrix}, \\ \gamma^3 &= i \begin{pmatrix} 0 & 1 \\ 1 & 0 \end{pmatrix}, & \gamma^5 &= i \begin{pmatrix} 0 & 1 \\ -1 & 0 \end{pmatrix}, \end{aligned} \tag{4.2}$$

where σ_μ are Pauli matrices. Under the assumption $P_3 \equiv 0$ and writing ψ as $\begin{pmatrix} \psi_1 \\ \psi_2 \end{pmatrix}$ it is obvious that eq. (4.1) can be written as the sum of the two independent equations for ψ_1 and ψ_2 ,

$$\begin{aligned} [i\tilde{\gamma}^\mu(\partial_\mu - ieA_\mu) + m]\psi_1 &= 0 \\ &(\mu = 0, 1, 2), \tag{4.3} \\ [i\tilde{\gamma}^\mu(\partial_\mu - ieA_\mu - m)\psi_2 &= 0 \end{aligned}$$

where $\tilde{\gamma}$ are the gamma matrices in 2 + 1 dimensions.

Then the original Dirac equation does not reduce to one Dirac particle in one less dimension but to two particles with opposite sign for the masses*. From the general formula (4.1) one can see that the anomalous current is cancelled between the two species.

In other words the mass term $m\bar{\psi}\psi = m(\psi_1^\dagger \sigma_3 \psi_1 - \psi_2^\dagger \sigma_3 \psi_2)$ as *invariant* under the generalized parity transformation $\psi_1 \rightarrow \sigma_1 \psi_2$ and $\psi_2 \rightarrow \sigma_1 \psi_1$. In the two-component formulation the mass term $m\psi_1 \psi_1$, for example, is *odd* under a parity transformation where $\psi_1 \rightarrow \sigma_1 \psi_1$.

This simple example teaches us that one must be very careful in the search for a physical realization of the parity anomaly (by the way, the above described model

* Since there is no matrix that anticommutes with all the Pauli matrices $\tilde{\gamma}^\mu$ we cannot solve the problem by a change of representation.

shows that the quantum Hall effect cannot be described by theories with Chern-Simons terms because the effect would be cancelled). For other criticisms to this possible connection, see refs. [5] and [6].

To continue our search for two-dimensional models with anomalous properties, we may try to work with some phenomenological hamiltonian on a lattice presenting degeneracy points where relativistic electrons emerge in the same spirit as in our example of sect. 1, but directly in 2 dimensions. For example, in ref. [7] a planar honeycomb lattice describing graphite was studied. However again a doubling problem is present: in the tight-binding approximation the separation between the valence and conduction band is minimal in two inequivalent points. The relativistic equation recovered around these points is again eq. (4.3) and the anomaly is cancelled. The reason for this cancellation can be found in the symmetries of the original hamiltonian. (There are other problems related with interplanar interactions that may even ruin the relativistic spectrum in graphite [17].)

Also in the context of lattice gauge theories it has been proven [21] recently that the continuum flavors of the staggered formulation [16] in odd dimensions, are divided into two equal groups with opposite signs in the mass term leading again to a zero current. In mathematical words, the representations of the Clifford algebra in even space-time dimensions are all equivalent while in odd dimensions there are two inequivalent representations differing in sign [22]. Then the construction of a thin layer of PbTe would not help (remember the relation between PbTe and the Kogut-Susskind formulation of lattice fermions).

We believe that all these examples are just consequences of a general result. In two space dimensions all the Bravais lattices have inversion symmetry. If a degeneracy point occurs at momentum $\mathbf{K} \neq \mathbf{0}$, another degenerate point will be present at $(-\mathbf{K})$ leading to Dirac equations

$$(\pm \boldsymbol{\gamma} \cdot \mathbf{K} + m)\psi_{\pm} = 0 \quad (4.4)$$

inducing anomaly cancellations (for the special case $\mathbf{K} = \mathbf{0}$, see ref. [23]).

However there is a way out of this problem; we have shown in sect. 3 that the solution is to work in three spatial dimensions and reduce the dimensionality by using a domain wall. As we have proved in the appendix, the degenerate flavors coming from the Kogut-Susskind hamiltonian, eq. (2.4), have all the same mass terms. They are all coupled to a soliton (s) or antisoliton (\bar{s}) but not one to s and another to \bar{s} which would have implied also a cancellation of the current after a γ_5 term is introduced in the theory to move the levels from 0. We have also shown that each of these 4 components flavors are reduced on the plane where the wall is to a two-component spinor due to the constraint $\gamma_3 \psi = i\psi$. Then our model in the presence of appropriate external fields develops a current of abnormal parity.

In the next section we discuss the experimental conditions in which this current should appear.

5. Symmetry breaking terms and relation to physical systems

In the previous chapters we have shown that the PbTe-type semiconductor with a domain wall or, in certain cases, with an open surface, represent a physical realization of the parity anomaly discussed in sect. 3. We reached this conclusion after considering a very simplified model of these substances. One of the major approximations has been the neglect of the Zeeman term (i.e. the electron's magnetic moment). The other is the fact that some of these materials undergo a Peierls distortion [15] which can play an important role. We will now discuss both cases. Naturally we are still neglecting other interactions like the coulombic one. These studies will be reported elsewhere. Both perturbations, Zeeman and Peierls, have a very important effect on the properties of a half-filled system. For this reason we should also consider the effects of a classical potential (i.e. different filling fractions).

5.1. ZEEMAN TERM

The Zeeman term has the form

$$H_z = \mu \mathbf{B} \cdot \sum_{\mathbf{r}, \alpha\beta} \psi_{\alpha}^{+}(\mathbf{r}) \boldsymbol{\sigma}_{\alpha\beta} \phi_{\beta}(\mathbf{r}), \quad (5.1)$$

where α and β run over both spin orientations. For the sake of simplicity we will assume that \mathbf{B} is perpendicular to the domain wall. The main effect of this term is to lift the spin degeneracy. Thus the zero-mode discussed in sect. 3 is now split between up and down spins. The system thus develops a magnetic moment (by filling up the spin up states which are lower in energy than the spin down states). However at the same time we have restored the spectral symmetry and thus charge conjugation. The result is that there is no induced charge and no anomalous current. Thus the Zeeman term can have an overwhelming effect even though it is very small in magnitude (of the order of 10^{-3} eV). Alternatively we may consider systems other than half-filled and vary the chemical potential by doping the system. Once the chemical potential is larger than μB , we will have a vanishing magnetic moment (the ground state is a singlet) and a net charge and thus an anomaly. The informed reader will notice the close analogy between our problem and polyacetylene-type systems in which a similar dichotomy is found – fractional charge and zero spin or zero charge and integer spin.

5.2. PEIERLS PERTURBATIONS

If the electron-phonon coupling constant is sufficiently strong a three-dimensional PbTe-type system can undergo a Peierls distortion. PbTe itself appears not to have a Peierls distortion down to low temperatures ($\sim 4^{\circ}\text{K}$). For systems with a rock-salt structure the main Peierls mode is a distortion along the major diagonals.

The final result is a staggered hopping term along the major diagonals. The extra term in the hamiltonian is

$$H_P = \frac{1}{2} \Gamma^{(s)} \sum_{\mathbf{r}, \alpha} (-1)^{x+y+z} \sum_{\{s_i\}} \phi_\alpha^+(\mathbf{r}) \left(\phi_\alpha \left(\mathbf{r} + \sum_{i=1}^3 \hat{e}_i s_i \right) + \text{h.c.} \right), \quad (5.2)$$

where $s_i = \pm 1$ and $i = 1, 2, 3$. Using the techniques summarized in the appendix we can show that the Peierls term is equivalent to a γ_5 mass term of the type used in sect. 3; c.f. eq. (3.9), with a constant amplitude $K = 2\Gamma^{(s)}/T$. As pointed out in sect. 3 this term breaks particle-hole symmetry and thus acts like an effective mass term for the “zero-modes”. The result is now that the sign of the anomalous current is the same as the sign of the Peierls term. Since the Peierls ground state is two-fold degenerate both sign are possible. As far as orders of magnitude are concerned the Peierls gap is 10^{-2} eV (the regular gap is 10^{-1} eV) while the Zeeman term is 10^{-3} eV. Thus a Peierls gap will always make the Zeeman term unimportant. We then conclude that in the presence of a Peierls distortion the ground state is a singlet (i.e. the magnetic susceptibility is zero) and that there are both an induced charge and an anomalous current in the presence of electromagnetic fields.

It is worthwhile to observe that a non-Peierls (i.e. non-staggered hopping) term along the major diagonals does break particle-hole symmetry but yields a term of the form $i\beta\gamma_5\nabla^2$ in the effective continuum hamiltonian. Thus such hopping terms do not affect the physics of the low lying states.

5.3 MAGNETIC SUSCEPTIBILITY

From the previous discussion we can conclude that the bound states on the wall in a (finite) magnetic field will have either zero magnetic moment and non-zero induced charge *or* non-zero magnetic moment and zero induced charge. In the first case, the situation for half-filled PbTe in a non-zero magnetic field, we expect a Curie-type susceptibility at high temperatures crossing over to zero susceptibility at zero field. For other filling fractions a net magnetic susceptibility will remain resulting in a Curie-like magnetic susceptibility down to zero temperature. In fact Volkov and Pankratov [24] have carried out a calculation that applies for this case. The applicability of their work (and ours) for PbTe-SnTe junctions is quite unclear due to the different nature of the electronic states in SnTe. On the other hand, if a Peierls distortion is present the system will be in a spin singlet state. For magnetic fields weaker than the Peierls gap there is no moment and, hence, zero susceptibility.

6. Conclusions

In this paper we propose that a semiconductor of the PbTe type with a domain wall is a physical realization of the parity anomaly of 2 + 1 dimensional electrodynamics. We found that the electronic states of this system can be described in terms of a simple tight-binding-model which in turn was shown to be equivalent to Kogut-Susskind fermions, a particular discretization of the Dirac equation. We have shown that, in the continuum limit, the problem reduces to the study of the electrodynamics of massive Dirac particles in the background of a soliton. Our study shows that either by doping the system or in the presence of a Peierls distortion a current of anomalous parity is present. It is proposed that these currents can be measured in a Hall-type experiment by reversing the magnetic fields. These anomalous currents do not change sign with the magnetic field unlike the Hall currents. Various symmetry breaking terms were also considered. In this paper Coulomb interactions have not been taken into account. It is quite likely that they will lead to interesting ground states with physical properties possibly analogous to those of the fractional Hall effect. These effects, as well as the presence of dislocations, are currently under study.

This work has been supported in part by an NSF grant DMR-84-15063 and by DOE contract DE-AC03-76SF00515.

Note added

In the context of lattice gauge theories, it is well known that a Wilson fermion [24] in 2 + 1 dimensions gives only one flavor in the continuum limit. The hamiltonian is,

$$H = \frac{1}{2} \sum_{x, \mu} \bar{\psi}(x) \gamma_{\mu} [\psi(x + \mu) - \psi(x - \mu)] \\ - \frac{1}{2} K \sum_{x, \mu} \bar{\psi}(x) [2\psi(x) - \psi(x + \mu) - \psi(x - \mu)],$$

where $x(\mu)$ are the sites (links) of a square lattice. K is a parameter and $\psi(x)$ is a two-component fermion operator. This H is *not* parity invariant [26]. It can be proved that the degeneracy point occurs at $\mathbf{k} = 0$ and there is no doubling. If one can find a phenomenological hamiltonian which in some limit corresponds to the Wilson's hamiltonian, then the anomalous current should be observable. We do not know of such a substance. This point deserves further analysis.

Appendix

In this appendix we show that the continuum limit of the hamiltonian, eq. (2.4), corresponds to two particles satisfying the Dirac equation with equal mass terms. We also show that this hamiltonian on the lattice has bound states localized over the wall as in the continuum limit. We will closely follow the original paper of Susskind where the reader is referred to for more details.

Our derivation is based on the equation of motion of the KS hamiltonian. By making adequate linear combinations of fields, the equations will decouple into two independent sets exhausting the low frequency spectrum of the theory.

The equation of motion of the hamiltonian, eq. (2.4), is:

$$i\dot{\psi}(r) = \frac{i}{2a} [\psi(r + e_z) - \psi(r - e_z)](-1)^{x+y} + \frac{i}{2a} [\psi(r + e_x) - \psi(r - e_x)] + \frac{1}{2a} [\psi(r + e_y) - \psi(r - e_y)](-1)^{x+y} + m(z)(-1)^{x+y+z}\psi(r). \quad (A.1)$$

It can be easily shown that there is a periodicity in the hamiltonian such that a cube plays the role of a unit cell. Then it is natural to relabel the field ψ as shown in fig. 3. The 8 new fields will form the 2×4 Dirac components of the two continuum flavors. They satisfy the equations,

$$\begin{aligned} \dot{f}_1 &= \Delta_z f_3 + \Delta_x f_4 - i\Delta_y g_4 + im(z)f_1, \\ \dot{f}_2 &= -\Delta_z f_4 + \Delta_x f_3 + i\Delta_y g_3 + im(z)f_2, \\ \dot{f}_3 &= \Delta_z f_1 + \Delta_x f_2 - i\Delta_y g_2 - im(z)f_3, \\ \dot{f}_4 &= -\Delta_z f_2 + \Delta_x f_1 + i\Delta_y g_1 - im(z)f_4, \end{aligned} \quad (A.2)$$

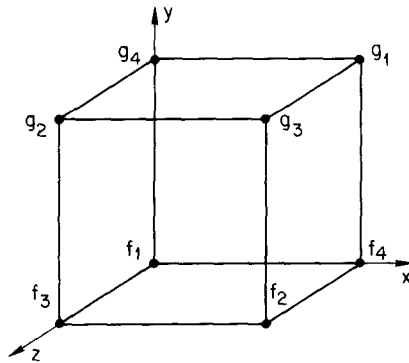

Fig. 3. Redefinition of the field ψ in a unit cell.

where

$$\Delta_j f_i(r) = \frac{1}{2} [f_i(r + e_j) - f_i(r - e_j)].$$

Interchanging g_i and f_i we obtain the equations for \dot{g}_i . Now note that by introducing the linear combinations:

$$\mu = \begin{pmatrix} f_1 + g_1 \\ f_2 + g_2 \\ f_3 + g_3 \\ f_4 + g_4 \end{pmatrix}, \quad d = \begin{pmatrix} f_2 - g_2 \\ g_1 - f_1 \\ g_4 - f_4 \\ f_3 - g_3 \end{pmatrix}, \quad (\text{A.3})$$

we can rewrite eq. (A.2) into two independent sets of equations. In fact defining $q = \begin{pmatrix} \mu \\ d \end{pmatrix}$ it can be easily proved that it satisfies the eigenvalue equation

$$[-i\alpha \cdot \Delta + m(z)\beta]q = Eq, \quad (\text{A.4})$$

where

$$\alpha = \begin{pmatrix} 0 & \sigma \\ \sigma & 0 \end{pmatrix}, \quad \beta = \begin{pmatrix} 1 & 0 \\ 0 & -1 \end{pmatrix}. \quad (\text{A.5})$$

Eq. (A.4) is a lattice version of the Dirac equation in 3 spatial dimensions for the two flavors μ and d . Note the important detail that the mass term in eq. (A.4) is equal for both flavors as remarked in sect. 4 [26]. This is a crucial result of our model. On the other hand, repeating the steps leading from (A.1) to (A.5) in two spatial dimensions one again obtains two continuum flavors (now with spinors of two components) but with different signs in the mass terms leading to cancellations of the anomalous current as discussed in sect. 4.

Now let us try to solve eq. (A.4) when $m(z)$ is a step function at $z = 0$. We will concentrate on the “zero-energy” bound state (for step function mass there is only one bound state). Following the similar calculation in the continuum (sect. 3) it is natural to look for solutions of the form,

$$f_i(x, y, z) = e^{iEt} e^{i(p_y y + p_x x)} e^{-Kx} f_i^+, \quad (\text{A.6})$$

where (p_x, p_y) is the transverse momentum, E is the energy, K and f_i^+ are

constants to be determined. For $z < 0$ we propose a similar ansatz but changing $K \rightarrow -K$ and $f_i^+ \rightarrow g_i^+$. Also the solution for g_i is equal in form to eq. (A.6) introducing the new constants g_i^\pm .

After some algebra we arrive to the 8×8 system of equations for f_i^+, g_i^+ :

$$\begin{aligned}
 Ef_1^+ &= P_3 f_3^+ + P_1 f_4^+ - iP_2 g_4^+ + mf_1^+ , \\
 Ef_2^+ &= -P_3 f_4^+ + P_1 f_3^+ + iP_2 g_3^+ + mf_2^+ , \\
 Ef_3^+ &= P_3 f_1^+ + P_1 f_2^+ - iP_2 g_2^+ - mf_3^+ , \\
 Ef_4^+ &= -P_3 f_2^+ + P_1 f_1^+ + iP_2 g_1^+ - mf_4^+ , \\
 Eg_1^+ &= P_3 g_3^+ + P_1 g_4^+ - iP_2 f_4^+ + mg_1^+ , \\
 Eg_2^+ &= -P_3 g_4^+ + P_1 g_3^+ + iP_3 f_3^+ + mg_2^+ , \\
 Eg_3^+ &= P_3 g_1^+ + P_1 g_2^+ - iP_2 f_2^+ - mg_3^+ , \\
 Eg_4^+ &= -P_3 g_2^+ + P_1 g_1^+ + iP_2 f_1^+ - mg_4^+ ,
 \end{aligned} \tag{A.7}$$

where $P_1 = \sin p_x$, $P_2 = \sin p_y$, $P_3 = i \operatorname{sh}(K)$. The equations for f_i^-, g_i^- are the same replacing $K, m \rightarrow -K, -m$.

Now it is convenient again to define fields u^+ and d^+ as in eq. (A.3). Using the matrices defined in eq. (A.5) it can be proved that

$$Eu^+ = (\boldsymbol{\alpha} \cdot \mathbf{P} + m\beta)u^+ \tag{A.8}$$

(the same equation is satisfied by d^+).

The spectrum is given by $E = \pm \sqrt{P^2 + m^2}$. In fact we are interested in the case $p_3^2 + m^2 = 0$, i.e.

$$\operatorname{sh}(K) = m. \tag{A.9}$$

From eq. (A.8) the spinor u^+ satisfy the equations

$$\gamma_3 u^+ = iu^+ , \tag{A.10a}$$

where $\gamma_3 = \beta\alpha_3$, and

$$(\alpha_1 P_1 + \alpha_2 P_2)u^+ = Eu^+ . \tag{A.10b}$$

A solution of these equations is

$$u^+ \propto \begin{pmatrix} 1 \\ a \\ i \\ -ia \end{pmatrix} \tag{A.11}$$

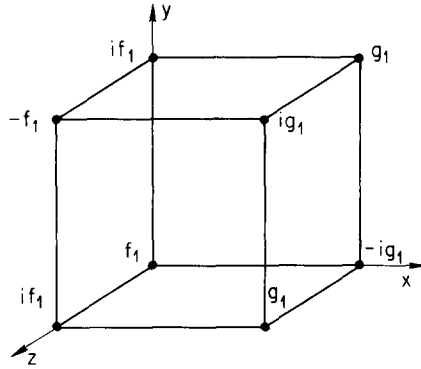

Fig. 4. Lattice wave function of the modes localized over the wall.

where $a = i(P_1 + iP_2)/E$. In terms of the site variables f_i^+, g_i^+ the solution (A.11) can be written as shown in fig. 4 where

$$f_1 = 1 - a, \quad g_1 = 1 + a \tag{A.12a}$$

and the exponential factor at every site is

$$\phi(x, y, z) = e^{i(p_y \cdot y + p_x \cdot x)} e^{-\text{arcsinh } m \cdot z} \tag{A.12b}$$

The solution for $z < 0$ is obtained from eq. (A.12) by reflection. Defining the 4×4 unitary transformation

$$U = \frac{1}{2} \begin{pmatrix} 1 & -i \\ -i & 1 \end{pmatrix} \tag{A.13}$$

it can easily be proved that (see eq. (3.4))

$$\psi_{\text{lattice}} = Uu^+ \phi(x, y, z) \xrightarrow{a \rightarrow 0} \psi_{\text{continuum}}.$$

Then all the conclusions of sect. 3 about the existence of localized bound states over the wall, induced charge, etc., can also be obtained in the lattice formulation.

References

- [1] S. Deser, R. Jackiw and S. Templeton, Phys. Rev. Lett. 48 (1982) 372
- [2] K. von Klitzing, G. Dorda and M. Pepper, Phys. Rev. Lett. 45 (1980) 494
- [3] R. Jackiw, Phys. Rev. D29 (1984) 2375
- [4] A. Friedman, et al., Phys. Rev. Lett. 52 (1984) 1587
- [5] A. Abouelssaood, Phys. Rev. Lett. 54 (1985) 1973
- [6] D. Boyanovsky, R. Blankenbecler and R. Yahalom, Nucl. Phys. B270 [FS 16] (1985)
- [7] G. Semenoff, Phys. Rev. Lett. 53 (1984) 2449

- [8] E. Fradkin, E. Dagotto and D. Boyanovsky, *Phys. Rev. Lett.* 57 (1986) 2967
- [9] C. Callan and J. Harvey, *Nucl. Phys.* B250 (1985) 427
- [10] T.L. Ho, J.R. Fulco, J.R. Schrieffer and F. Wilczek, *Phys. Rev. Lett.* 52 (1984) 1524
- [11] M. Stone, A. Garg and P. Muzikar, *Phys. Rev. Lett.* 55 (1985) 2328
- [12] A.V. Balatsky, G.E. Volovik and V.A. Konyshel, Landau Institute preprint (1985)
- [13] R. Jackiw and J.R. Schrieffer, *Nucl. Phys.* B190 [FS3] (1981) 253, published in *Handbook on Conducting Polymers*, ed. T. Shothheim (Dekker, New York 1984);
R. Jackiw and C. Rebbi, *Phys. Rev.* D13 (1976) 3398;
A. Niemi and G. Semenoff, *Phys. Rev.* D30 (1984) 809; *Phys. Rev. Lett.* 51 (1983) 2077;
D. Boyanovsky et al., ref. [6]
- [14] W.P. Su, J.R. Schrieffer and A. Heeger, *Phys. Rev. Lett.* 42 (1979) 1698
- [15] R. Dornhaus, G. Nimitz and B. Schicht, *Springer Tracts in Modern Physics*, vol. 98 (Springer, 1985)
- [16] L. Susskind, *Phys. Rev.* D16 (1977) 3031
- [17] H. Nielsen and N. Ninomiya, *Phys. Lett.* B130 (1980) 389
- [18] J.S. Bell and R. Rajaraman, CERN preprint TH.3340 (1982), unpublished
- [19] K. Fujikawa, *Phys. Rev. Lett.* 42 (1979) 1195; *Phys. Rev.* D21 (1983) 2848
- [20] T. Appelquist, M. Bowick, D. Karabali and L. Wijewardhana, *Phys. Rev.* D33 (1986) 3704
- [21] C. Burden and A. Burkitt, Australian National University preprint ANU-HEP-29 (1986)
- [22] M. Sohnius, *Phys. Reports* 128 (1985) 39 [appendix A]
- [23] K. Wilson, *New phenomena in subnuclear physics*, ed. A. Zichichi, Erice (1975) (Plenum, New York)
- [24] B.A. Volkov and O.A. Pankratov, *JETP Lett.* 42 (1985) 178
- [25] E. Dagotto, *Phys. Rev.* D34 (1986) 2457
- [26] H. Kluberg-Stern, A. Morel, O. Napoly and B. Petersson, *Nucl. Phys.* B220 (1983) 447;
J. Kogut, M. Stone, H. Wyld, S. Shenker, J. Shigemitsu and D. Sinclair, *Nucl. Phys.* B225 (1983) 326