

An Alternative Evaluation of Oscillation-Based Test. A Case Study

José Peralta¹, Marcelo Costamagna¹, Gabriela Peretti^{1,2}, Mónica Lovay¹, Eduardo Romero^{1,2}, Carlos Marqués²

¹ Mechatronics Research Group, Facultad Regional Villa María, Universidad Tecnológica Nacional. Av. Universidad 450, 5900 Villa María, Argentina
jmperalta.pepe@gmail.com, costamagna_m@frvm.utn.edu.ar, mlovay@gmail.com.

² Electronics and Instrumentation Development Group, Facultad de Astronomía, Matemática and Física, Universidad Nacional de Córdoba, Medina Allende s/n, 5000 Córdoba, Argentina
{eduardo.abel.romero, gabita.peretti}@gmail.com, marques@famaf.unc.edu.ar

Abstract. In this work, we evaluate the ability of Oscillation-Based Test (OBT) for detecting in continuous-time filters, more realistic parametric faults. As a case study, we consider a low pass fourth order leapfrog filter. We use a fault simulation based on Monte Carlo and redefine a fault coverage metric to globally characterized OBT. The fault model applied assumes that only one component can be faulty while the others adopt random values within their tolerance bands. Statistical deviations in the values of the fault-free components are considered in order to obtain a more accurate evaluation of the test technique under study. The fault coverage data obtained show high values only for high deviation faults and presents significant differences for positive and negative deviations. In addition, the metric also reveals that some of the components of the filter under study can be considered as hard to test.

Keywords: Oscillation-based test, continuous-time filters, fault coverage, parametric faults.

1 Introduction

Considerable research has been devoted to the development of test methodologies for the sub-systems commonly used in analog and mixed-signal applications. The analog and mixed-signal sections, especially those usually embedded in systems that are complex typically require a relatively low silicon area but generate the major test challenges because of the low observability of the internal nodes and the nature of the involved signals. Generally, a good test system requires a significant effort that is not related to the dimensions of the circuit [1].

Traditional test techniques for filters are based on the verification of their functional specifications, for example the limits of the pass-band and the attenuation in the stop-band. However, this process is very time consuming and severely affects

the cost of the product. For this reason, alternative test techniques have been formulated mainly oriented to consider the test problem as an integral part of the design process. A number of test techniques can be found in the literature, normally based on some kind of reconfiguration and the addition of extra circuitry for implementing the test.

Oscillation-Based Test is an interesting test strategy for analog and mixed signal circuits that does not need resources for stimulus generation and requires simple circuits for the measurements of the test attributes. These two characteristics make possible the implementation of Built-In Self-Test (BIST). Moreover, if the test resources added to the circuit are reused is possible to realize recurring tests during the operation of the Circuit Under Test (CUT) in field. Authors in [2] formerly proposed this test strategy based in the conversion of the CUT into an oscillator. In the test mode, the behavior of the CUT can be evaluated by monitoring the amplitude and frequency of the oscillating signal parameters. OBT assumes that a fault in the circuit will show some changes in those parameters, making them observable.

OBT was successfully applied filters by these and others authors [3], [4], [5], [6]. In these papers, the ability of OBT for detecting single deviation faults in the filters is evaluated, reaching good values of fault coverage. These values are obtained assigning nominal values to the non-faulty components, a simplification that allows implementing fault simulations in a very straightforward way. However, the metrics obtained following this approach do not take into account the natural variability of devices caused by many factors, such as manufacturing processes, aging and surrounding environment. This fact could lead to fault coverage values that overestimate or underestimate the efficacy of the test scheme.

In this paper, parametric faults are defined as out-of tolerance deviations in the process, circuit or system parameters. For detecting parametric faults, the statistical deviations in the values of the fault-free components should be considered in order to obtain a more accurate evaluation of the test technique under study.

Several researchers have developed new parametric fault models and simulation techniques for analogue circuits. In [7], it is considered that all circuit parameters can vary within their tolerance limits and only the faulty one adopts a value outside these limits. A similar single fault model and an algorithm for reducing the computational cost of fault-simulations are proposed in [8]. Other researchers [9] related this model with the specifications in order to remove some of them for reducing the test time.

In [10] the authors present a statistical test development approach for analog circuits. They model a parametric fault distribution in a process parameter as an impulse function, at the faulty value (a mean shift with zero standard deviation). They assume that the parametric fault falls into two neighboring regions of a fault-free tolerance window while the other process parameters vary with Gaussian distribution inside the fault-free tolerance window.

The authors of [11], [12], [13] employ multiple-deviation fault-models to evaluate the efficiency of test strategies (different from functional test) for discriminating out-of specification circuits. For this task, they assume that the low-level circuit parameters present a Gaussian distribution, and consider different test scenarios by means of increasing the variability of the parameters. Other authors [14], [15], define

several metrics for evaluating the efficacy of test strategies under the hypothesis of parametric faults.

In this work, we evaluate the ability of OBT for detecting more realistic faults in continuous-time filters. To this end, we adopt as a case study a fourth order filter, a fault simulation based on Monte Carlo and a redefined fault coverage value.

2 OBT implementation

The application of OBT requires converting the CUT into a robust oscillator. We adopt the non-linear oscillators that have been successfully applied in SC filters [3], [5].

Fig. 1 shows a conceptual diagram of the implemented oscillator, based on connecting a Non-Linear Block (NLB) from the main filter output to the filter input. NLB presents an abrupt characteristic, and can be easily implemented using a comparator.

In the figure, S1 to S4 are analogue switches employed for switching the filter from the test-mode to the normal-mode and vice versa. In normal mode S1 and S3 are switched-on while S2 and S4 are switched-off. In this way, the filter input is connected to the normal input and the filter output is connected to the following stage of the application. In test mode, S1 and S3 are switched-off and S2 and S4 are switched-on. Consequently, the filter input is connected to the NLB output, and the system is configured as oscillator.

As the filters present attenuation for high frequencies, we employ the describing function approach [16] to analyze the system behavior and to find the oscillation parameters in an easy way. This method allows a rapid “first cut” design of the oscillators. The procedure for establishing the oscillation conditions using this approach is addressed elsewhere [6].

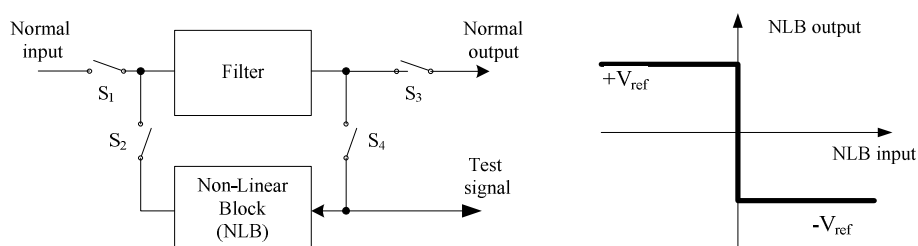

Fig. 1. Implementation scheme for OBT.

3 Filter under test

In order to evaluate the ability of OBT for testing parametric faults, a fourth order low pass filter has been chosen as test vehicles. The topology of this filter is shown in Fig.

2. The frequency and the amplitude of the signal output are the OBT parameters to be measured in test mode with a V_{ref} value of 1V (Fig. 1).

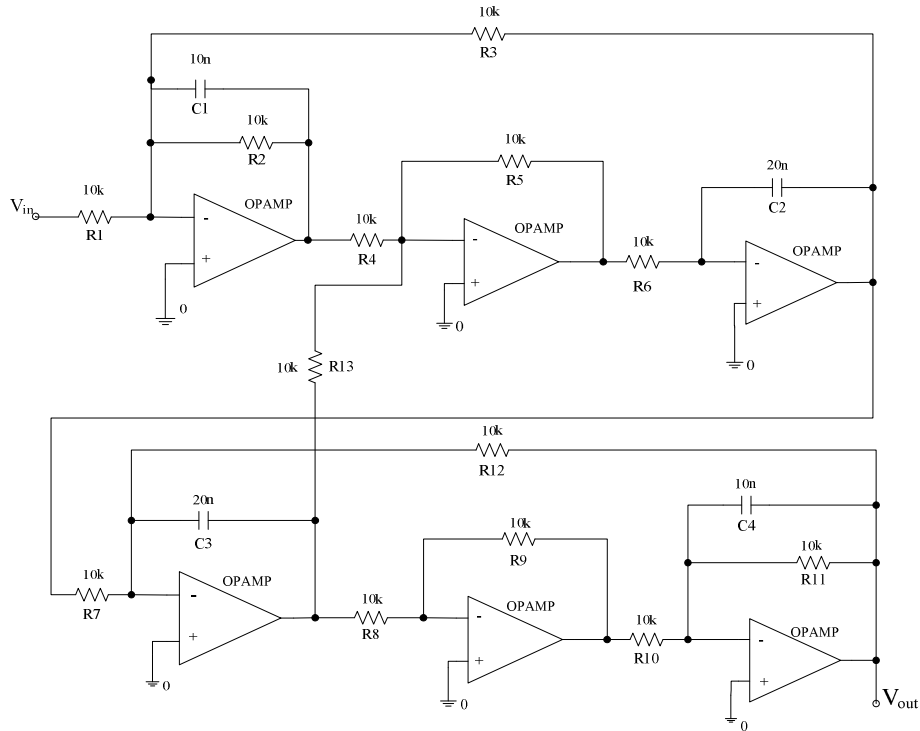

Fig. 2: Leapfrog filter under test

4 Fault Simulation and Metric Evaluation

4.1 Fault Model Adoption and Simulation Process

In this work, for the evaluation of the ability of OBT to detect deviation faults in the filter passive components, we adopt the fault model proposed by [7]. This model considers that only one component can be faulty while the others adopt random values within their tolerance bands (obtained from their statistical distributions).

The fault is introduced by assigning a deterministic value outside the tolerance band of the faulty component. Fig. 3 illustrates the behavior of the fault injected in any of the components of the filter (resistances, denoted by R_i where $i = 1 \dots n$ and capacitors denoted by C_j , where $j = 1 \dots m$). For the filter under study, the total number of components is $n+m$, with $n = 2$ and $m = 7$.

In our experiments, for any capacitor and resistor we consider twelve deviation faults (df_k), defined in (1). Each deviation in df_k corresponds to a separate fault. They are expressed as percentage of the nominal value of the fault free component.

$$df_k = \{-50, -45, -35, -25, -20, -10, +10, +20, +25, +30, +35, +45, +50\} . \quad (1)$$

The values of the test attributes considered in the assessment of the test strategy are obtained running several simulations under different conditions. First, a simulation is done considering fault free components in the circuit; second, various simulations are run using the fault model described above. Several 500-sample the Monte Carlo simulations are run using the Monte Carlo analysis available in the Spice simulator software.

During the fault free simulation process, the component values behave as random variables with normal distributions (Fig. 3). The distribution mean (\bar{X}) takes the nominal value of the components shown in Fig. 2. The standard deviation (σ) is a typical value for the manufacturing process. For all components, σ is considered as 1.665% of the mean ($3\sigma = 5\%$). It is assumed that there are no correlations between the components of the CUT.

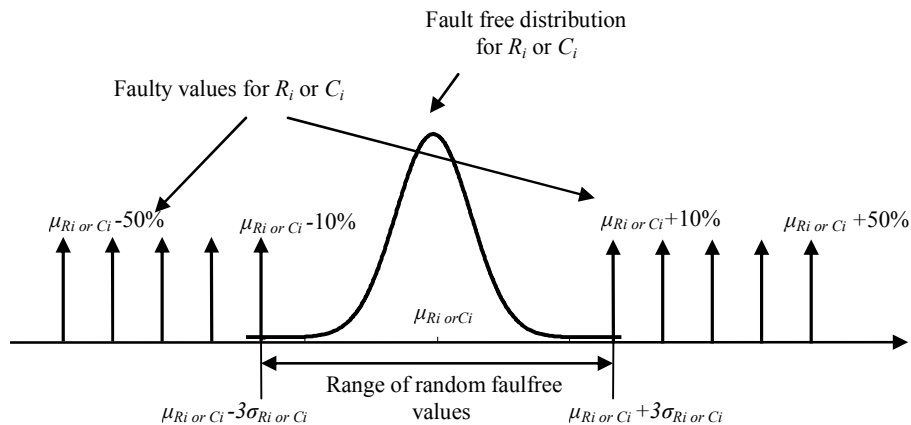

Fig. 3. Normal distribution for a fault free component and uniform distribution for the faulty component (R_i or C_j). Each impulse represents a separate parametric fault.

4.2 Limits of Test Attributes for the Fault-Free Circuit

The test parameter values obtained by simulation under fault free conditions show a statistical distribution with a set of values within an interval which limits are called Statistical Tolerance Limits (STL). These limits are calculated depending on the type of the test attribute distribution. The expression (2) is used if the distribution is normal, where k is a constant which values are tabulated such that in a large proportion γ of the intervals, at least $100(1-\alpha)\%$ of the distribution will be included [17]. The value of k also depends on the sample size.

$$\bar{X} \pm k\sigma \quad (2)$$

If the distribution is not normal, the STL are calculated as nonparametric statistical limits. These limits do not depend on the distribution of the variable and are valid for any continuous probability distribution. They are based on the largest and smallest observations in the sample.

For testing normal distribution of data we use the Shapiro-Wilk (S-W) test. This statistic tests the null hypothesis that a sample comes from a normally distributed population. Table 1 summarizes the results of S-W test for the test attribute data.

Table 1. p-values for normality S-W test and decisions on null hypothesis at a confidence level of 0.95 for the test attribute samples.

Test Parameter	p-value	Decision
Frequency (Hz)	0.014	Null hypothesis rejected
Amplitude (V)	0.45	Null hypothesis not rejected

On these basic criteria, the STL for the frequency are calculated non-parametrically. The minimum value in the sample corresponds to the Lower Statistical Tolerance Limit (LSTL) and the maximum value corresponds to the Upper Statistical Tolerance Limit (USTL). For the amplitude, a normal distribution is considered. LSTL and USTL are calculated using the expression (2) where $k=2.72$. Table 2 shows STL for 99% of population ($\alpha=0.01$) at a confidence level of 95% ($\gamma=0.95$) [17].

Table 2. STL for amplitude and frequency (99% of population at a confidence level of 95%).

Test Attribute	LSTL	USTL
Frequency (Hz)	1.24	1.59
Amplitude (V)	0.34	0.69

4.3 Fault Detection Probability (FDP) and Valuation of Test Metrics

As it was set up earlier, the elements of the simulated samples under fault condition are considered as different instances of the filter. They are obtained when a df_k value is assigned to the faulty component of the CUT, while the others adopt random values (with Gaussian distribution) within their tolerances. The fault injected in the component during simulation is declared as detected when the circuit presents test attribute values beyond the STL. We use the following estimator (3) to evaluate the test detection probability,

$$FDP_{i \text{ or } j}(df_k) = NDF_{i \text{ or } j} / NIF_{i \text{ or } j} \quad (3)$$

In (3), $FDP_{i \text{ or } j}(df_k)$ denotes the probability of detecting the k^{th} deviation fault (df_k) injected in any component (R_i or C_j). $NDF_{i \text{ or } j}$ is the sum of the detected faults for

components i or j and $NIF_{i \text{ or } j}$ is the sum of the injected faults in the components (equivalent to the dimension of the generated sample).

In order to obtain a test metric for the global characterization of OBT for the filters under study, we adopt the one suggested by [8]. The fault coverage is defined as the average of the fault detection probabilities obtained for each deviation level (4).

$$FC(df_k) = \sum_1^{n+m} FDP_{i \text{ or } j}(df_k) / (n+m) . \quad (4)$$

In (4), $FC(df_k)$ is the fault coverage for the df_k deviation fault. $n+m$ is the number of components (R_i and C_j) considered in the fault injection. The summation is for all the components in the circuit. It should be noted that this metric allows a global evaluation of OBT, but it is not useful to reveal the hard-to-test components.

5 Fault Simulation Results

The results obtained after fault simulations are resumed in Table 3 (considering the frequency as the only test attribute) and Table 4 (considering the amplitude as the only test attribute).

For frequency measurements, the detectable defective components are, R_5 , R_6 , C_2 and C_3 (Table 3) whose FDP values rise to more than approximately 85% for deviations below -40%. R_{13} has a notable FDP of 78% but for a deviation below -50%. R_1 , R_2 , R_{11} , as well as R_9 and C_4 are almost undetectable for positive or negative deviations. In general, FDP values are greater for larger deviations and for negative deviations. For positive deviations, R_5 and C_2 present the highest detection values that only rise to approximately 65% for +50% fault deviation.

By other way, when amplitude is measured (Table 4), R_1 , R_2 , R_7 and R_{11} are the components with the highest fault detection probability. The worst profile is for R_6 . R_{13} , C_2 , C_3 and C_1 and C_4 are almost no detectable. For positive deviations, R_1 , R_2 and R_{11} are detectable, but their FDP values reach barely 50%. The rest of the components are almost undetectable for negative deviations.

Table 3. FDP values (%) for oscillation frequency measurements, components R_1 to R_9 .

Dev. (%)	R_1	R_2	R_3	R_4	R_5	R_6	R_7	R_8	R_9
-50	0.0	1.0	58.8	63.6	99.2	100	62.8	61.8	32.2
-40	0.0	1.2	27.4	25.6	84.4	90.2	25.4	21.8	18.4
-30	0.0	1.0	15.4	14.2	50.8	58.6	14.0	13.0	10.0
-20	0.0	1.4	1.0	1.0	16.8	8.2	1.0	4.2	2.0
-10	0.0	0.2	0.0	0.0	2.4	5.2	0.0	0.0	0.0
10	0.0	0.0	1.4	0.0	1.0	2.6	1.0	1.0	0.0
20	1.8	1.0	3.0	1.0	3.8	11.0	4.0	3.0	1.0
30	1.6	1.4	4.2	4.6	32	30.4	5.0	8.6	7.2
40	1.0	0.0	6.0	7.8	37.6	48.8	6.8	8.2	6.8
50	0.0	1.0	13.2	10.4	64.2	64.0	10.4	10.0	8.8

Table 3. (continued) *FDP* values (%) for oscillation frequency measurements, components R_{10} to R_{13} and C_1 to C_4

Dev. (%)	R_{10}	R_{11}	R_{12}	R_{13}	C_1	C_2	C_3	C_4
-50	61.0	0.0	58.8	78.2	48.4	100	100	25.8
-40	19.2	2.0	20.6	23.6	10.6	90.6	92.2	9.2
-30	14.0	2.0	15.0	15.0	8.0	60.0	60.0	7.0
-20	1.0	0.0	1.0	1.0	2.4	6.2	6.8	2.4
-10	0.0	0.0	0.0	0.0	0.0	1.0	2.0	1.0
10	0.0	0.0	0.0	0.0	1.0	2.0	2.0	0.0
20	2.0	0.0	1.0	1.0	3.0	8.0	10.8	3.0
30	6.2	2.0	5.4	6.2	8.6	29.0	28.2	9.0
40	7.0	1.0	8.4	6.8	9.8	45.6	44.8	9.8
50	10.6	0.0	11.8	9.8	7.6	66.4	63.2	15.4

Table 4. *FDP* values (%) for oscillation amplitude measurements, components R_1 to R_9

Dev. (%)	R_1	R_2	R_3	R_4	R_5	R_6	R_7	R_8	R_9
-50	100	92.8	73.6	28.8	27.6	1.2	99.4	30.4	66.4
-40	98.2	48.6	38.2	18.6	4.6	0.0	66.6	26.8	36.4
-30	70.2	16.2	6.0	11.4	2.4	0.0	42.8	6.6	6.2
-20	18.4	4.2	2.2	3.6	0.0	0.0	10.4	3.0	4.0
-10	4.8	2.2	1.0	1.8	0.0	0.0	2.0	0.8	2.8
10	1.2	3.2	0.0	1.8	0.0	0.0	1.0	1.2	2.8
20	3.0	5.2	2.0	3.4	1.0	0.0	2.8	0.0	3.0
30	10.6	18.2	6.8	1.8	2.4	0.0	5.6	2.8	5.8
40	23.8	40.8	11.8	8.2	18.8	0.0	14.2	6.6	11.8
50	51.2	51.6	12	8.4	20.8	1.2	31.2	8.0	13.4

Table 4. (continued) *FDP* values (%) for oscillation amplitude measurements, components R_{10} to R_{13} and C_1 to C_4

Dev. (%)	R_{10}	R_{11}	R_{12}	R_{13}	C_1	C_2	C_3	C_4
-50	27.8	94.8	75.6	2.6	11.8	6.8	3.6	19.8
-40	22.8	60.8	58.8	1.2	4.8	4.4	2.2	12.6
-30	9.2	20.4	8.4	0.0	1.0	2.2	1.8	1.2
-20	2.6	3.8	2.0	0.0	0.0	1.0	0.0	0.0
-10	1.0	1.2	1.8	1.0	2.0	2.0	2.2	0.0
10	2.0	1.8	1.6	0.0	0.2	1.0	2.0	1.0
20	0.0	4.4	2.0	1.0	1.0	0.8	1.0	0.0
30	2.0	15.6	7.8	1.4	2.8	2.2	2.6	2.2
40	4.6	34.8	12.6	4.4	0.0	6.4	8.4	4.6
50	7.8	55.8	13.4	4.8	0.0	16.6	23.0	6.0

The joint assessment of frequency and amplitude shows better results for detecting faults in the components of the filter under test (Table 5). The table shows that for negative deviations fault detection is higher than for positive deviations. For high negative deviations, only C_1 , C_4 have low FDP . Nevertheless, the components that show a very good FDP for deviations near -50% (near 100% for R_1 , R_2 , R_5 , R_6 , R_7 , R_{11} , R_{12} , C_2 and C_3 and 75% to 93% for R_3 , R_4 , R_8 , R_9 , R_{10} , R_{11} , R_{13}) show a different profile in their behavior versus the deviation size. Only R_1 has a good FDP below deviations of -30%. In the other cases, FDP drops rapidly to detection values below 50%. For deviations between -20% and +20% FDP values are much below 20% for most components. For deviations higher than +50%, R_1 , R_2 , R_5 , R_6 , R_{11} , C_1 and C_2 shows values over 50%. In general, for high deviations, FDP values are greater than for small deviations (positive or negative). For less than 20% (positive or negative deviations) the detection of fault components is less than 25%. C_1 and C_4 present low FDP values for all deviation faults injected and can be considered as hard to detect.

Table 5. FDP values (%) for the joint evaluation of frequency and amplitude, components R_1 to R_9 .

Dev. (%)	R_1	R_2	R_3	R_4	R_5	R_6	R_7	R_8	R_9
-50	100	92.8	93.8	84.2	98.6	100	100	85.2	75.2
-40	98.2	48.4	46.2	38.2	84.6	90.0	85.2	34.2	37.2
-30	70.2	16.2	20.0	22.8	50.8	58.6	49.4	18.2	15.0
-20	18.4	4.2	2.0	3.6	16.8	8.2	10.8	5.2	4.2
-10	4.8	2.2	1.0	1.8	0.8	2.4	5.2	2.0	0.8
10	1.2	3.4	0.8	3.2	1.8	0.0	1.0	1.2	2.4
20	4.2	6.2	5.4	4.4	3.8	10.6	6.2	3.0	4.2
30	10.6	18.2	10.2	5.0	33.4	30.6	10.2	10.6	11.2
40	23.8	40.8	13.2	15.2	55.8	48.8	15.2	12.2	12.0
50	51.2	51.6	23.0	25.8	60.2	63.6	35.4	17.4	19.2

Table 5. (continued) FDP values (%) for the joint evaluation of frequency and amplitude, components R_{10} to R_{13} and C_1 to C_4 .

Dev. (%)	R_{10}	R_{11}	R_{12}	R_{13}	C_1	C_2	C_3	C_4
-50	85.6	94.8	97.4	78.2	49.6	100	100	34.2
-40	30.4	60.6	73.8	23.6	14.8	90.6	92.2	13.4
-30	20.7	21.6	20.4	15.4	9.6	42.8	40.2	8.2
-20	2.8	3.8	1.0	0.8	2.4	6.6	6.8	2.4
-10	2.8	1.0	1.2	1.8	1.0	2.0	2.6	0.8
10	0.0	1.6	1.6	0.0	0.2	3.0	3.6	1.0
20	2.2	3.8	3.8	2.2	3.8	7.6	11.2	4.0
30	8.2	16.5	11.8	7.2	9.8	29.2	27.6	10.2
40	10.0	34.8	18.6	9.2	11.0	45.6	44.8	12.4
50	16.2	55.2	23.2	13.0	17.2	65.6	62.6	20.8

6 Fault Coverage (FC) Evaluation

Table 6 displays the FC considering the joint evaluation of amplitude and frequency versus the fault deviation percentages assigned to components of the filters. In general, FC is higher for positive deviations. The FC values decrease more rapidly for negative deviations and rise more rapidly too for positive deviations. Moreover, FC for small deviations is extremely low and we may say that faulty components are almost undetectable.

Table 6. FC (%) in terms of fault deviation.

Fault deviation, df_k (%)	FC (%)	Fault deviation, df_k (%)	FC (%)
-50	85.8	10	1.6
-40	56.1	20	5.0
-30	30.2	30	14.8
-20	5.9	40	25.3
-10	2.0	50	35.7

Even though this average used to characterize OBT describes the general behavior of the fault coverage metric, the variability pattern of the FC mean at each deviation level hides particularities associate to some of the components. As an example, according to Table 6 the filter under test has a FC of near 90% for -50% deviation faults. Nevertheless, for this deviation level and for most of components the FDP is near 90% or more; five components show values between 75% and 85%, and two components show FC less than 50%. On the other hand, for small deviations, the FC is a very good metric to evaluate the ability of OBT to detect faulty components in the CUT due to the low variability of the FC results.

Fig. 4 shows the performance of the metric used to evaluate OBT strategy and greatly improves the appreciation of the FC in the quality assessment process of this metric. Markers in Fig. 4 depict the FDP for each component and the line depicts the test FC versus fault deviations.

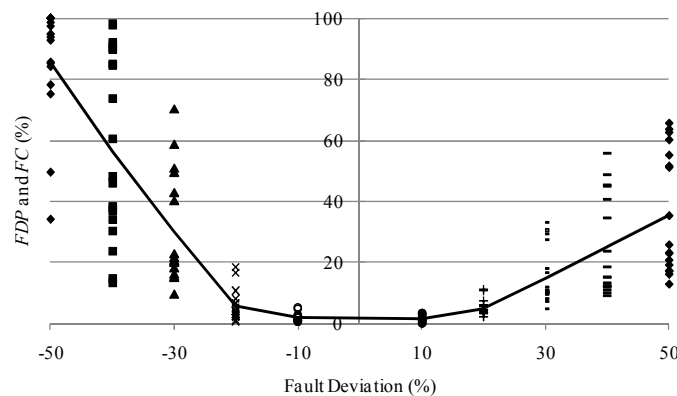

Fig. 4. Graphic evaluation of FC

7 Conclusions

In this paper, we evaluate the ability of OBT for detecting parametric faults in the components of leapfrog filter adopted as a case study. Extensive fault Monte Carlo simulations were performed in order to calculate the fault detection probability for each component and to characterize the *FC* metric used in this work. The results obtained showed that the probabilities of detecting component faults are more significant when the frequency and the amplitude are jointly evaluated. The *FDP* allows the characterization of OBT performance for each component of the filter and it is useful for revealing hard to test components. In general, their values are high only for high deviations. *FC* could be considered as a good metric to global characterize the OBT performance, but it must be handled with care. Variability of *FDP* is large for high deviations and the approach used to calculate *FC* hides these variations.

References

- [1] Vinnakota, B.: Analog and Mixed-Signal Test. Prentice Hall, New Jersey (1998).
- [2] Arabi, K., Kaminska, B.: Oscillation-Test Strategy for Analog and Mixed-Signal Integrated Circuits. In: Proceedings of the 14th. VLSI Test Symposium, pp. 476-482 (1996).
- [3] Huertas, G., Vázquez, D., Peralías, E., Rueda, A, Huertas, J.: Practical Oscillation-Based Test of Integrated Filters. IEEE Design &Test of Computers vol. 19, pp. 64-72, (2002).
- [4] Romero, E., Peretti, G., Huertas, J., Vázquez, D.: Test of Switched-Capacitor Ladder Filters Using OBT. Microelectronics J., vol. 36, pp. 1073-1079 (2005).
- [5] Peretti, G. , Romero, E., Marqués C.: On the Ability of OBT for Detecting Deviation Faults in SC Ladder Filters. J. Electrical Eng., vol. 90, pp. 127-141 (2007).
- [6] Catalano, J., Peretti, G. , Romero, E., Marqués C.: Exploring the Ability of Oscillation Based Test for Testing Continuous-Time Ladder Filters. In: Proc. 7th. International Symposium on Quality Electronic Design (ISQED'06), pp. 543-550 (2006).
- [7] Saab, K., Ben-Hamida, N., Kaminska, B.: Parametric Fault Simulation and Test Vector Generation. Proc. Conf. on Design, Automation and Test in Europe, pp. 650-656 (2000).
- [8] Khouas, A., Derieux, A.: Fault Simulation for Analog Circuits under Parameter Variations. J. Electron Test, vol. 16, pp. 269-278 (2000).
- [9] Chang, S., Lee, C., Chen, J.: Structural Fault Based Specification Reduction for Testing Analog Circuits. J. Electron Test, vol. 18, pp 571-581 (2002).
- [10] Liu, F., Ozev, S.: Statistical Test Development for Analog Circuits under High Process Variations. IEEE Trans. Comput. Aided Des. Integr. Circuits Syst., vol. 36, pp. 1465-1477 (2007).
- [11] Raghunathan, A., Chun, J., Abraham, J., Chatterjee, A.: Quasi-Oscillation-Based Test for Improved Prediction of Analog Performance Parameters. Proc. Int. Test Conf., pp. 252-261 (2004).
- [12] Chaehoi, A., Bertrand, Y., Latorre, L., Nouet, P.: Improving the Efficiency of the Oscillation-Based Test Methodology for Parametric Faults. IEEE Latin American Test Workshop, pp. 234-237 (2003).

- [13] Chaehoi, A., Latorre, L., Azais, F., Nouet, P.: Use of a statistical approach for efficient implementation of Oscillation-Based Test Strategy. In: Proc. 9th. Int. Mixed Signal Test Workshop, pp. 99-103 (2003).
- [14] Sunter, S., Nagi, N.: Test Metrics for Analog Parametric Faults. Proc. 17th. VLSI Test Symposium, pp. 226-234 (1999).
- [15] Bounceur, A., Mir, S., Simeu, E., Rolíndez, L.: Estimation of Test Metrics for the Optimisation of Analogue Circuit Testing. J. Electron Test, vol. 23, pp 471-484, (2007).
- [16] Gibson, J.: Nonlinear Automatic Control. McGraw-Hill, Japan (1963).
- [17] Mitra, A.: Fundamentals of Quality Control and Improvement, 2nd. Ed. Prentice Hall, New Jersey (1998).